



Empowering Energy-Water Nexus Resilience: Addressing Hydroelectric Micro-turbine Barriers

Jennifer Sklarew, Ph.D.
Department of Environmental Science and Policy
&
Eli Watkins
Department of Physics
Zoe Waide
Volgenau School of Engineering
Heather Nortz
Department of Environmental Science and Policy
George Mason University

Mason Energy Symposium
April 26, 2018



The Problem: Resilience of Interdependent Systems

- Energy & water systems face many resilience challenges.
 - Technological & infrastructure vulnerabilities
 - Institutional struggles
 - Supply-demand balance uncertainties
- System interdependence can compound these challenges.
- Communities facing severe energy & water insecurity = especially vulnerable.

Leveraging Interdependence: Hydropower Micro-turbines as a Solution

- When placed in pipes for drinking water or storm water runoff, turbines can:
 - ✓ promote potable water & storm water management
 - ✓ concurrently bolster local electricity supply
 - ✓ overcome challenging trade-offs between water & energy system resilience

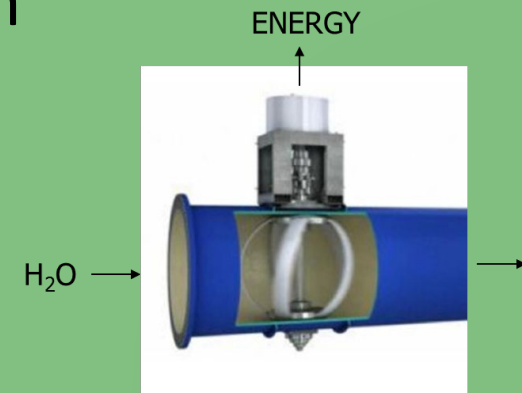

Research Question: Identifying and Addressing Barriers

- What features are needed to deploy hydroelectric micro-turbines in urban areas facing energy and water insecurity?
 - ✓ Technological
 - ✓ Geographical
 - ✓ Ecological
 - ✓ Institutional
 - ✓ Socio-economic

Hypotheses

- Challenges to hydropower micro-turbine deployment vary by location.
- Institutional relationships can create, worsen or mitigate these challenges, hindering or enabling their deployment.
- Creating a transparent process with community involvement in identifying solutions to local challenges can enable hydropower micro-turbine features that foster energy & water system resilience.

Methodology:

Phase 1: On-Campus Pilot

- Build & deploy 2 micro-turbines in storm water runoff pipes on Mason's Fairfax campus.
- Identify technical, geographical, ecological, institutional & socio-economic challenges.
- Identify & assess potential solutions.
- Use pilot's energy output to test & assess small-scale urban applications, e.g., emergency lighting & cell phone charging stations.

Multidisciplinary Approach

Project Team

Disciplines

<ul style="list-style-type: none">• College of Science (COS)• Volgenau School of Engineering (VSE)• College of Humanities & Social Sciences (CHSS)	<ul style="list-style-type: none">• Environmental science & policy• Physics• Geography & geoinformation science• Forensic Science• Civil, infrastructure & environmental engineering• Mechanical engineering• Electrical engineering• Sustainability studies• Global affairs
--	--

Student Roles in Mason Pilot

- Turbine design, construction & deployment
 - Identify turbine construction challenges
 - Analyze turbine replication potential
 - Test & assess small-scale electricity applications
 - Analyze deployment challenges & solutions
 - Develop lessons transferable to other communities
- Educational programs & signage
 - Promote institutional & community support
 - Perpetuate energy-water resilience education

Mason Pilot Candidate Sites

1. Test different flows, elevations, & pipe diameters
 2. Develop different designs to meet varied site parameters
 3. Test electricity applications in different locations
- Outflow pipe from Mason Pond
 - Existing body of water
 - Water always present
 - Pipe that collects runoff from Shenandoah Parking Deck
 - Urban environment
 - Intermittent flow

Rainfall and Energy Analysis:
Shenandoah Parking Deck Site
by Eli Watkins and Zoe Waide

Example of work:

Rainfall: .23 in/day

-> which has total volume change of

2051.75 ft³/day

->which has total mass of

58143.83 kg/day

->which has total kinetic energy of

5711.68 kJ

-> which is **1.60 kWh**

3 POTENTIAL DESIGNS

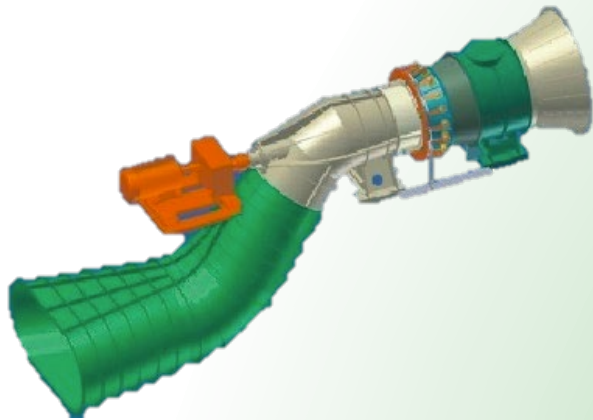

KAPLAN S TYPE

- Good for places with large variance in flow

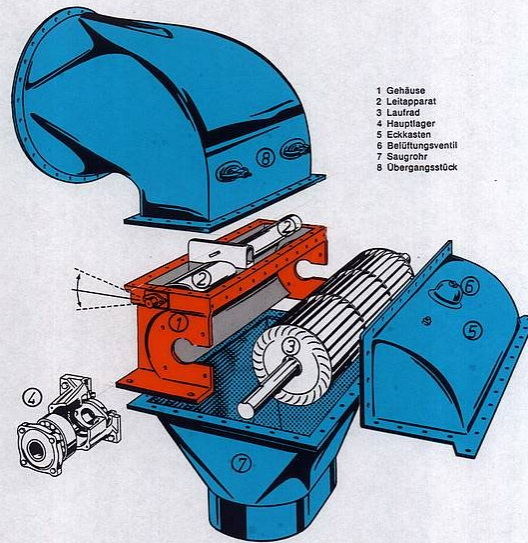

CROSSFLOW TURBINE

- Good for wide range of head heights
- efficient at low flow
- Easy to manufacture

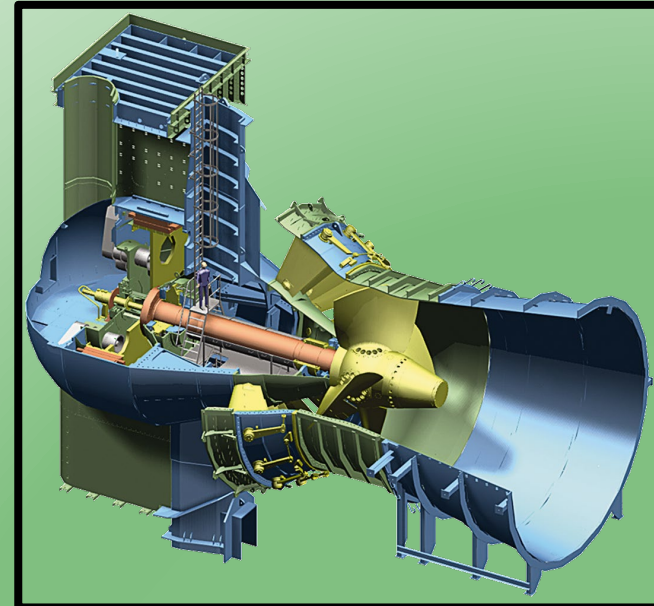

BULB TURBINE

- Wide range of head heights

Current Energy Output Findings from Mason Pilot by Eli Watkins and Zoe Waide

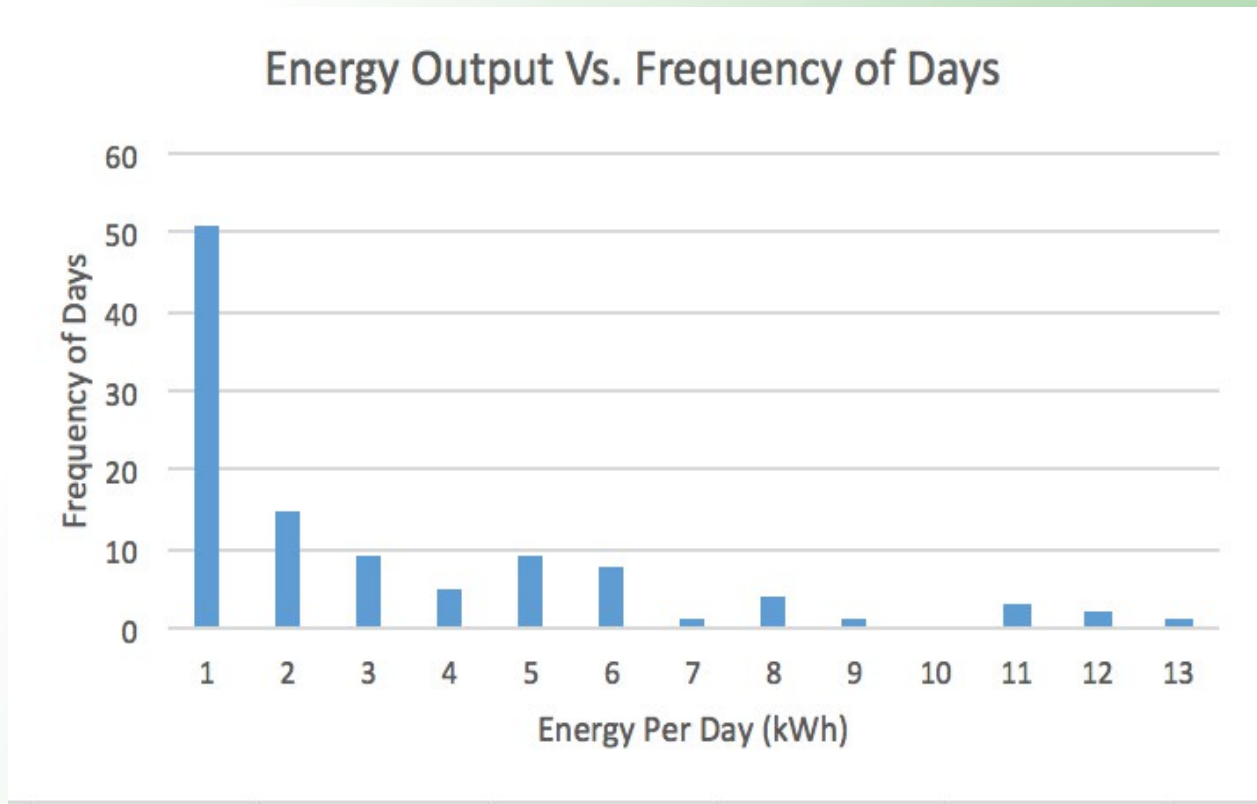

Cell phone chargers use an average of 3.64 watts when charging.

Phase 2: International Pilot

- Findings will be applied in a developing nation pilot:



Ghana

1990-2012:

+34% Power, +30% H₂O



India

1990-2012:

+28% Power, +22% H₂O

India's Microhydro Turbine Use

Case Study by Heather Nortz

- Existing hydroturbines are mainly used for power generation
 - Archived over 90 existing small to micro hydro projects
 - Some for mitigating flooding
- Main focus on Institutional considerations
 - Funding comes mainly from private sector
 - Community involvement leads to the success of the project
- Looking Forward with Mason's pilot project
 - Find areas prone to flooding and in need of drinking water
 - assess considerations at a local level

Authors and Acknowledgements

- This presentation describes an interdisciplinary research project conducted by faculty members from Mason's College of Science and the Volgenau School of Engineering: Jennifer Sklarew, Colin Reagle, Viviana Maggioni, Paul Houser, Dann Sklarew, and Celso Ferreira.
- Water sensor data collection funded by a grant from Mason's College of Science.
- Mason campus turbine construction, installation, monitoring, electricity connection, and educational signage funded by a grant from Mason's Patriot Green Fund.



Questions?

Jennifer Sklarew, Ph.D.
Department of
Environmental Science and Policy
George Mason University
jsklarew@gmu.edu

References

- Ailawadi, V. S. and Subhes C. Bhattacharyya. 2006. Access to energy services by the poor in India: Current situation and need for alternative strategies. *Natural Resources Forum*, Vol 30, Issue 1: 2–14.
- Arora, D. S. , Sarah Busche, Shannon Cowlin, Tobias Engelmeier, Hanna Jaritz, Anelia Milbrandt, and Shannon Wang. 2010. *Indian Renewable Energy Status Report Background Report for DIREC 2010 NREL/TP-6A20-48948*.
- Brown, Dennis. Notre Dame finalizes agreement to construct hydro facility on St. Joseph River. *Notre Dame News*. December 12, 2016.
- Clark, Alix, Mark Davis, Anton Eberhard, Katharine Gratwick & Njeri Wamukonya. 2005. *Power sector reform in Africa: assessing the impact on poor people*. The Graduate School of Business, University of Cape Town for ESMAP/World Bank.
- Jones, Lindsey. Introduction to the Local Adaptive Capacity Framework. Overseas Development Institute.
- Kellogg, Karen and Caroline Hobbs. A Case Study of Small Hydropower. *The Solutions Journal*. Vol. 7, Issue 1. March 16: 46-54.
- Lawrence Berkeley National Laboratory. Standby Power. *Standby Power Summary Table*,2018, standby.lbl.gov/summary-table.html.

Nath, Anita. 2011. India's Progress Toward Achieving the Millennium Development Goals. *Indian Journal of Community Medicine*, Vol. 36, Issue 2: 85–92.

Programme Evaluation Organization Planning Commission, Government of India. November 2010. *Evaluation Study on the Rajiv Gandhi National Drinking Water Mission*.

Therrein, Jim. Two small hydropower sites planned in North Bennington. VT Digger. April 9, 2017. <https://vtdigger.org/2017/04/09/two-small-hydropower-sites-planned-north-bennington/>

United Nations Development Programme. 2012. 2010 Ghana Millennium Development Goals Report.

Water Network. 2013. *Ghana Market Assessment: Market-Based Provision of Water at the Community Level, Executive Summary*.

The World Bank Group. *Expanding Electricity Access by Mobilizing Local Resources: Analysis of Models for Improving Rural Electricity Services in India through Distributed Generation and Supply of Renewable Energy*. Mumbai. February 15, 2011.